



US 20060014044A1

(19) **United States**

(12) **Patent Application Publication** (10) **Pub. No.: US 2006/0014044 A1**
Ko (43) **Pub. Date: Jan. 19, 2006**

(54) **ORGANIC LIGHT-EMITTING DISPLAY
WITH MULTIPLE LIGHT-EMITTING
MODULES**

Publication Classification

(75) Inventor: **Chung-Wen Ko**, Xi-Zhi City (TW)

(51) **Int. Cl.**
H05B 33/12 (2006.01)
(52) **U.S. Cl.** **428/690**; 428/917; 313/504;
313/506; 257/88; 257/E51;
438/34; 427/66

Correspondence Address:
DUANE MORRIS, LLP
IP DEPARTMENT
30 SOUTH 17TH STREET
PHILADELPHIA, PA 19103-4196 (US)

(57) **ABSTRACT**

An organic light-emitting device (OLED) includes an anode, a cathode and a plurality of organic light-emitting units. The organic light-emitting units are separated by a charge transfer layer which may be formed of various fullerenes in combination with a further material. The charge transfer layer may be a relatively homogenous layer that is a mixture of fullerene and the further material or it may include two distinct layers including a fullerene layer and a layer of the further material.

(73) Assignee: **AU OPTRONICS CORPORATION**

(21) Appl. No.: **10/892,017**

(22) Filed: **Jul. 14, 2004**

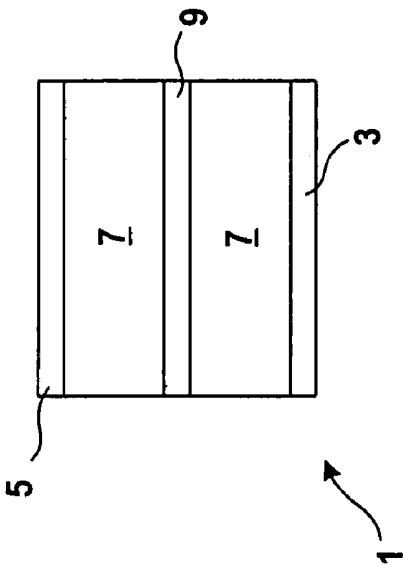
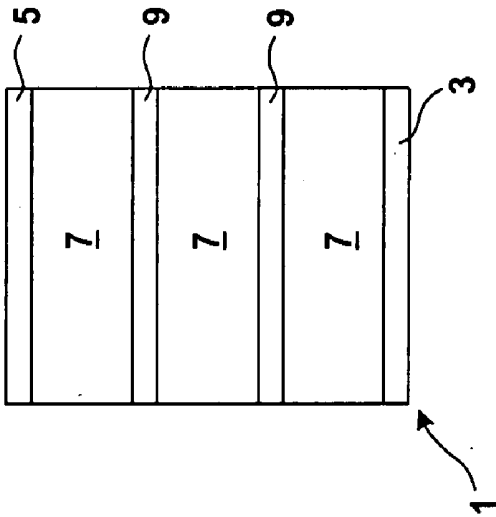
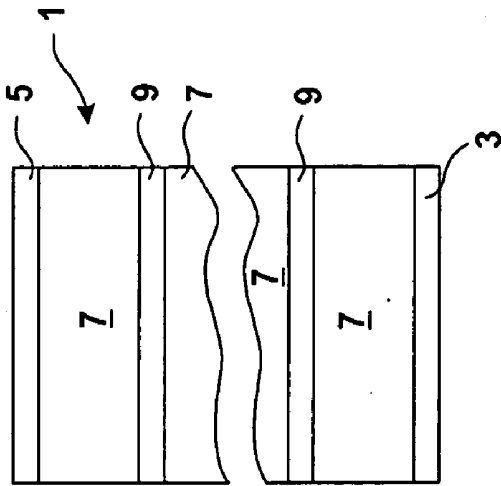

FIG. 1

FIG. 2

FIG. 3

ETL	<u>19</u>
EML	<u>17</u>
HTL	<u>15</u>
HIL	<u>13</u>

7

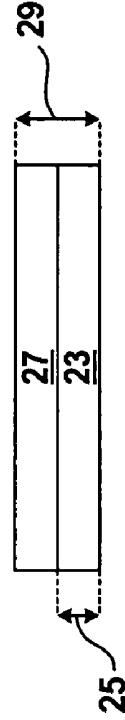

FIG. 4

FIG. 5

ORGANIC LIGHT-EMITTING DISPLAY WITH MULTIPLE LIGHT-EMITTING MODULES

FIELD OF THE INVENTION

[0001] The present invention relates to electroluminescent displays, and more particularly to organic light-emitting devices and a method of manufacturing such devices.

BACKGROUND

[0002] Organic light-emitting devices, for example organic light-emitting diodes (OLEDs), are broadly researched and utilized for their application in flat-panel displays. Flat-panel displays employing organic light-emitting devices are brighter than liquid crystal displays (LCDs) because organic light-emitting devices can emit light themselves and do not require backlight systems. Additionally, with different organic materials, organic light-emitting devices can emit light in red, green and blue colors with high luminance efficiency. Moreover, organic light-emitting devices can operate with low driving voltages and are viewable from oblique angles.

[0003] Organic light-emitting devices are usually structured to have a number of layers, including a unit of organic light-emitting material, sandwiched between an anode and a cathode. Buffer layers are often included between the organic light-emitting material and the anode and/or cathode. The unit of organic light-emitting material may consist of multiple layers which typically include an electron transport layer (ETL), an emissive layer (EML), a hole transport layer (HTL) and a hole injection layer (HIL). The basic principle of operation for an organic light-emitting device is that, when a voltage is applied across the anode and cathode, electrons and holes are driven to move to the organic light-emitting material. The electrons and holes meet and emit light. More particularly, when a migrating electron drops from its conduction band potential to a valance band potential in filling a hole, energy is released in the electroluminescent emissive layer as light, which is observable through the light-transmissive substrate upon which the organic light-emitting devices are formed. U.S. Pat. Nos. 6,137,223, 6,579,629, and 6,013,384 are expressly incorporated by reference herein in their entireties, for their teachings on organic light-emitting devices.

[0004] Limitations of the present organic light-emitting devices are due to the single organic light-emitting unit that is conventionally used. For example, the characteristics of the single organic light-emitting unit determine the efficiency of the optical light emitting device and the maximum achievable luminescence and brightness. The present invention addresses this limitation.

SUMMARY OF THE INVENTION

[0005] To achieve these and other objects, and in view of its purposes, the present invention provides an organic light-emitting device comprising a light-transmissive substrate, an anode, a cathode, and a plurality of organic light-emitting units disposed between the anode and the cathode. Adjacent organic light-emitting units are separated by a charge transfer layer that may advantageously include one or more fullerenes. In another embodiment, the charge transfer layer may be formed of two materials including an electron donating material and an electron accepting material.

[0006] In another exemplary embodiment, the present invention provides an organic light-emitting device comprising a light transmissive substrate, a light-transmissive anode disposed over the substrate, a first organic light-emitting unit disposed over the anode, a charge transfer layer including fullerene disposed over the first organic light-emitting unit, a second organic light-emitting unit disposed over the charge transfer layer, and a cathode disposed over the second organic light-emitting unit.

[0007] In yet another exemplary embodiment, the present invention provides a method for forming an organic light-emitting device. The method includes forming an anode over a light transmissive substrate, forming a cathode over the anode, forming a plurality of organic light-emitting units between the anode and the cathode, and forming a charge transfer layer between each adjacent set of the light emitting units, each charge transfer layer including fullerene.

BRIEF DESCRIPTION OF THE DRAWING

[0008] The present invention is best understood from the following detailed description when read in conjunction of the accompanying drawing. It is emphasized that, according to common practice, the various features of the drawing are not necessarily to scale. On the contrary, the dimensions of the various features are arbitrarily expanded or reduced for clarity. Like numerals denote like features throughout the specification and drawing.

[0009] **FIG. 1** illustrates a schematic view of an exemplary embodiment of an organic light-emitting device of the present invention;

[0010] **FIG. 2** illustrates a schematic view of another exemplary embodiment of an organic light-emitting device of the present invention;

[0011] **FIG. 3** is a cut-away view representing a general structure of the organic light-emitting device of the present invention;

[0012] **FIG. 4** illustrates a schematic view of an exemplary organic light-emitting unit used in the organic light-emitting device of the present invention; and

[0013] **FIG. 5** is a schematic view showing an exemplary charge transfer layer of the present invention.

DETAILED DESCRIPTION

[0014] Light is produced when holes and electrons combine to emit energy in an organic light-emitting material that emits light as electromagnetic radiation in response to the energy released by the recombination of the electron-hole pair. Stated alternatively, the organic light-emitting structure emits light in response to the application of an electric potential difference across the anode and cathode, such potential difference causing electrons from the cathode to travel toward the anode and holes from the anode to travel toward cathode, the electrons and holes meeting and recombining in an organic light-emitting layer formed of an electroluminescent material. **FIG. 1** shows an exemplary light emitting device that includes two organic light-emitting units separated by a charge transfer layer. **FIG. 2** shows another exemplary organic light-emitting device that includes three organic light-emitting units, each adjacent set of organic light-emitting units separated by a charge transfer

layer. **FIG. 3** is a cut-away view generally depicting a concept of the invention and represents that the organic light-emitting device of the invention includes a plurality of organic light-emitting units, each adjacent set of organic light-emitting units separated by a charge transfer layer. Each of the embodiments shown in **FIGS. 1-3** illustrates organic light-emitting device **1** including anode **3** and cathode **5**. Anode **3** and cathode **5** are each electrodes and in an exemplary embodiment, anode **3** may be formed over a light transmissive substrate (not shown) which may be formed of glass, quartz, plastics or other suitable materials. Anode **3** may be formed of conductive, light transmissive material such as indium tin oxide (ITO) or other suitable materials and cathode **5** may be formed of various suitable metals. Anode **3** may alternatively be formed of a thin opaque material. In each exemplary embodiment, organic light-emitting device **1** may additionally include an optional buffer layer or layers disposed between cathode **5** and the closest organic light-emitting unit **7** and/or between anode **3** and the adjacent organic light-emitting unit **7**.

[0015] Referring to **FIGS. 1-3**, charge transfer layer **9** is disposed between adjacent organic light-emitting units **7**. An exemplary organic light-emitting unit **7** such as may be used in the structures of **FIGS. 1-3**, is shown in more detail in **FIG. 4** and an exemplary charge transfer layer **9** is shown in more detail in **FIG. 5**. Organic light-emitting unit **7** may consist of three, four, or other numbers of layers in various exemplary embodiments. **FIG. 4** shows organic light-emitting unit **7** including four layers: hole injection layer **HIL 13**, hole transport layer **HTL 15**, emissive layer **EML 17**, and electron transport layer **ETL 19**. In another exemplary embodiment, the hole injection layer **13** may not be used and organic light-emitting unit **7** may therefore consist of three layers. Various thicknesses and various materials may be used to form these layers, and representative materials are described in previously incorporated U.S. Pat. No. 6,579,629. Hole injection layer **13** and hole transport layer **15** are formed of, or doped with, P-type material, and hole injection layer **13** is advantageously a P+ material. Electron transport layer **19** and emissive layer **17** are N-type materials, or doped with N-type dopants, and electron transport layer **19** is advantageously an N+ type material. Various suitable dopants are available to suitably dope hole injection layer **13**, hole transport layer **15**, emissive layer **17** and electron transport layer **19**. Emissive layer **17** is formed of an electroluminescent material that emits light when an electron-hole pair recombines in this layer.

[0016] **FIG. 5** shows an exemplary charge transfer layer **9**. In one exemplary embodiment, charge transfer layer **9** comprises a first material or a second material. The first material may be fullerene, FeCl₃, SbCl₅, tetra-cyanoquinodimethane (TCNQ), or F4-TCNQ or other materials with strong abilities to accept electrons, and the second material is an electron donating material such as lithium (Li), sodium (Na), potassium (K), cesium (Cs), magnesium (Mg), calcium (Ca), silver (Ag), aluminum (Al), nickel (Ni), tetrathiafulvalenes (TTF), or bis(ethylenedithio)tetrathiafulvalenes (BEDT-TTF). The fullerene may be buckminsterfullerene which includes 60 carbons and is thusly designated C60. In other exemplary embodiments, the fullerene may include different numbers of carbons such as C70, C76, C78, C82, C84, C90 and C96. In still another exemplary embodiment, charge transfer layer **9** is formed of an n-type electron accepting first material and a p-type electron-donating sec-

ond material. In one embodiment, charge transfer layer **9** is formed of a first material of at least one of fullerene, FeCl₃, SbCl₅, tetra-cyanoquinodimethane (TCNQ), or F4-TCNQ or other materials with strong abilities to accept electrons, and a second material that is an electron donating material such as lithium (Li), sodium (Na), potassium (K), cesium (Cs), magnesium (Mg), calcium (Ca), silver (Ag), aluminum (Al), nickel (Ni), tetrathiafulvalenes (TTF), or bis(ethylenedithio)tetrathiafulvalenes (BEDT-TTF).

[0017] In one exemplary embodiment such as shown in **FIG. 5**, charge transfer layer **9** may be formed of two distinct layers such as first layer **23** formed of one of the first or second materials and second layer **27** formed of the other of the first or second materials. According to this exemplary embodiment, first layer **23** may include a thickness **25** within the range of 1-200 nanometers and charge transfer layer **9** may have an overall thickness **29** within the range of 1-500 nanometers, but other thicknesses may be used in other exemplary embodiments. In another exemplary embodiment, charge transfer layer **9** may be formed of a generally homogenous single layer formed of a mixture of the first and second materials, with the first material included at a weight percentage ranging from 0.5-99.5% by weight. According to this exemplary embodiment, the first material may advantageously be fullerene. In one exemplary embodiment, the first material may be a p-type material or a triarylamine also used to form hole transport layer **15** or hole injection layer **13**, in one or more of the organic light-emitting units **7**.

[0018] In one exemplary embodiment, at least one of the organic light-emitting units **7** may include the hole injection layer **13** and/or the hole transport layer **15** formed of CuPc, copper phthalocyanine or NPB (4,4-bis-[N-(1-Naphthyl)-N-Phenylamino]-bi-phenyl), but other suitable materials may be used.

[0019] The invention also provides a method for forming the various described organic light-emitting device structures using deposition processes to sequentially form each of the aforementioned films. The method generally includes forming an anode over a light transmissive substrate, forming a cathode over the anode, forming a plurality of organic light-emitting units between the anode and the cathode, and forming a charge transfer layer between each adjacent set of the light emitting units, which themselves may be formed using a sequence of operations. Chemical vapor deposition (CVD), physical vapor deposition (PVD), sputtering, thermal evaporation, e-beam deposition, or other conventional methods may be used to form the sequence of films over a transparent substrate.

[0020] The preceding merely illustrates the principles of the invention. It will thus be appreciated that those skilled in the art will be able to devise various arrangements which, although not explicitly described or shown herein, embody the principles of the invention and are included within its spirit and scope. Furthermore, all examples and conditional language recited herein are principally intended expressly to be only for pedagogical purposes and to aid the reader in understanding the principles of the invention and the concepts contributed by the inventors to furthering the art, and are to be construed as being without limitation to such specifically recited examples and conditions. Moreover, all statements herein reciting principles, aspects, and embodiments of the invention, as well as specific examples thereof,

are intended to encompass both structural and functional equivalents thereof. Additionally, it is intended that such equivalents include both currently known equivalents and equivalents developed in the future, i.e., any elements developed that perform the same function, regardless of structure.

[0021] This description of the exemplary embodiments is intended to be read in connection with the figures of the accompanying drawing, which are to be considered part of the entire written description. In the description, relative terms such as “lower,” “upper,” “front,” “rear,” “horizontal,” “vertical,” “above,” “below,” “up,” “down,” “top” and “bottom” as well as derivatives thereof (e.g., “horizontally,” “downwardly,” “upwardly,” etc.) should be construed to refer to the orientation as then described or as shown in the drawing under discussion. These relative terms are for convenience of description and do not require that the apparatus be constructed or operated in a particular orientation.

[0022] Although the invention has been described in terms of exemplary embodiments, it is not limited thereto. Rather, the appended claims should be construed broadly, to include other variants and embodiments of the invention, which may be made by those skilled in the art without departing from the scope and range of equivalents of the invention.

What is claimed is:

1. An organic light-emitting device comprising a light transmissive substrate, an anode, a cathode and a plurality of organic light-emitting units disposed between the anode and the cathode, adjacent organic light-emitting units separated by a charge transfer layer.

2. The organic light-emitting device as in claim 1, wherein the charge transfer layer comprises fullerene.

3. The organic light-emitting device as in claim 1, wherein the charge transfer layer comprises a first material being one of fullerene, FeCl_3 , SbCl_5 , TCNQ, and F4-TCNQ, and a second material.

4. The organic light-emitting device as in claim 3, wherein the second material comprises at least one of TTF, BEDT-TTF, lithium, sodium, potassium, cesium, magnesium, and calcium, silver, aluminum, and nickel.

5. The organic light-emitting device as in claim 3, wherein the charge transfer layer is a single layer being a mixture of the first material and the second material, the first material composed of fullerene and constituting 0.5 to 99.5 percent of the mixture.

6. The organic light-emitting device as in claim 3, wherein each organic light-emitting unit comprises an electron transport layer, an emissive layer, a hole transport layer, and a hole injection layer, and at least one of a hole transport layer and hole injection layer is formed of CuPc or NPB.

7. The organic light-emitting device as in claim 2, wherein the fullerene includes a structure comprising one of C60, C70, C76, C78, C82, C84, C90, and C96.

8. The organic light-emitting device as in claim 2, wherein the charge transfer layer comprises a fullerene layer and a hole transport layer.

9. The organic light-emitting device as in claim 8, wherein the hole transport layer comprises a p-type dopant material.

10. The organic light-emitting device as in claim 9, wherein the p-type dopant material comprises TCNQ, F4-TCNQ, FeCl_3 , or SbCl_5 .

11. The organic light-emitting device as in claim 8, wherein the charge transfer layer includes a thickness within a range of 1-500 nm and the fullerene layer includes a thickness within a range of 1-200 nm.

12. The organic light-emitting device as in claim 3, wherein the charge transfer layer is formed of a first layer of the first material and a second layer of the second material.

13. The organic light-emitting device as in claim 1, wherein the charge transfer layer is formed of an electron donating material and an electron accepting material.

14. The organic light-emitting device as in claim 1, wherein each organic light-emitting unit comprises an electron transport layer, an emissive layer formed of electroluminescent material, and a hole transport layer.

15. The organic light-emitting device as in claim 14, wherein the organic light-emitting unit further comprises at least one hole injection layer.

16. The organic light-emitting device as in claim 1, further comprising at least one buffer layer disposed adjacent the cathode.

17. The organic light-emitting device as in claim 1, wherein a first organic light emitting unit is formed on the anode, the charge transfer layer is formed on the first organic light emitting unit, a second organic light emitting unit is formed on the charge transfer layer and the cathode is formed on the second organic light emitting unit, the anode, first organic light emitting unit, charge transfer layer, second organic light emitting unit and cathode arranged in parallel.

18. The organic light-emitting device as in claim 1, wherein the anode is formed of one of indium tin oxide, a further light transmissive material and an opaque material.

19. An organic light-emitting device comprising a light transmissive substrate, an anode formed of a light-transmissive material disposed over the substrate, a first organic light-emitting unit disposed over the anode, a charge transfer layer including fullerene disposed over the first organic light-emitting unit, a second organic light-emitting unit disposed over the charge transfer layer, and a cathode disposed over the second organic light-emitting unit.

20. A method for forming an organic light-emitting device comprising forming an anode over a light transmissive substrate, forming a cathode over the anode, forming a plurality of organic light-emitting units between the anode and the cathode, and forming a charge transfer layer between each adjacent set of the light emitting units, each charge transfer layer including fullerene.

* * * * *

专利名称(译)	有机发光显示器，带有多个发光模块		
公开(公告)号	US20060014044A1	公开(公告)日	2006-01-19
申请号	US10/892017	申请日	2004-07-14
[标]申请(专利权)人(译)	友达光电股份有限公司		
申请(专利权)人(译)	友达光电股份有限公司		
当前申请(专利权)人(译)	友达光电股份有限公司		
[标]发明人	KO CHUNG WEN		
发明人	KO, CHUNG-WEN		
IPC分类号	H05B33/12 C09K11/06 H01L51/00 H01L51/52 H05B33/14 H05B33/20		
CPC分类号	B82Y10/00 H01L51/0046 H01L51/0051 H01L51/5278 H01L51/0059 H01L51/0078 H01L51/0052		
外部链接	Espacenet USPTO		

摘要(译)

有机发光装置 (OLED) 包括阳极，阴极和多个有机发光单元。有机发光单元由电荷转移层隔开，电荷转移层可以由各种富勒烯与另外的材料组合形成。电荷转移层可以是相对均匀的层，其是富勒烯和其他材料的混合物，或者它可以包括两个不同的层，包括富勒烯层和另外的材料层。

